

INTREPID CONTROL SYSTEMS, INC.

ValueCAN3

Field Tested: 1000s Sold Worldwide!

ValueCAN3 delivers value by being a simple, low cost, high performance, and high quality tool for connecting your PC to a Controller Area Network (CAN) bus. It has become a low cost standard for many large corporations including automotive, military, industrial networking, and heavy commercial vehicle OEMs and their suppliers. ValueCAN3 has proven itself in a wide range of applications and environments.



Quality is what you expect and deserve

ValueCAN3 was designed as a high quality CAN tool solution. ValueCAN3 is fully isolated from the PC and includes certified drivers for Windows XP, 2000, and Vista. ValueCAN3's isolation layer is self powered from USB which eliminates the need for external power for the CAN transceiver.

ValueCAN3's isolation, a feature not common on low cost interfaces, resolves issues with grounding or noise affecting your PC and its communications. ValueCAN3 is also electrically hardened to survive an abusive environment including reverse battery and electrical transients. To make wiring easy, the device pin-out is printed clearly on the housing. Finally, ValueCAN3 is backed by a 1 year warranty.

High Performance

Are you running your networks at 1 Mbit per second with a high utilization rate? If you are, you can count on ValueCAN3. ValueCAN3 has been tested and verified to operate on high bandwidth CAN networks. This includes 100% utilization at 1Mbit on both channels. This performance is enabled by including a large 1 megabyte buffer on the device.

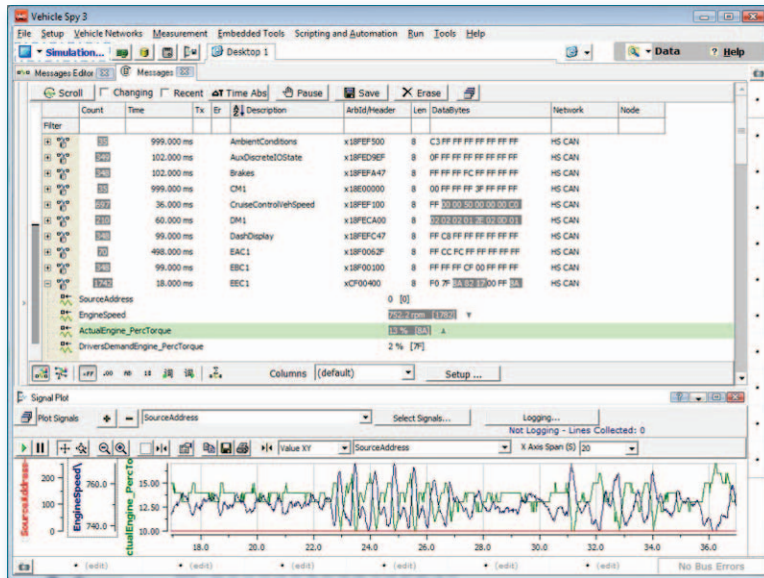

ValueCAN 3 includes Vehicle Spy trial edition for monitoring and saving CAN traffic.

Real Time Acceleration

ValueCAN3 has the ability to load real time scripts created with Vehicle Spy Professional. These scripts then execute in real time at microsecond resolution. The scripts can be controlled and monitored with a PC application.

High Level Protocols Supported

J1939, OBD2 on CAN, Keyword Protocol over CAN, UDS diagnostics, DeviceNet, and CANOpen are all compatible with ValueCAN. We offer cables for J1939 and automotive diagnostics on CAN.

Software Support: Turn-Key

A copy of Vehicle Spy 3 Trial Edition is included with ValueCAN3. This program is a powerful vehicle bus analyzer for monitoring messages and configuring baud rates. The professional user will want to upgrade to the full Vehicle Spy 3 software. Vehicle Spy lets you filter traffic, decode message data, build scripts, simulate other nodes, and build graphical displays of your data.

Software Support: Create Your Application Using the Included Intrepid DLL API, J2534 API, or RP1210 API

For those who wish to write their own applications, ValueCAN3 includes a DLL and helpful examples for Visual C++, Borland C++ Builder, LabWindows CVI, LabVIEW, Java, MATLAB, Delphi, Excel, and Visual Basic. For more information on the DLL, please see the neoVI DLL documentation (ValueCAN uses the neoVI DLL).

Intrepid Control Systems, Inc.

31601 Research Park Drive Madson Heights, MI 48071 USA (ph) +1-586-731-7950 (fax) +1-586-731-2274

www.intrepidcs.com

ValueCAN3

Specifications

- USB Operating System Support: Windows ME / 2000 / XP / Vista / Linux
- ISO11898 dual wire CAN Physical Layer (TJA1040x2) compatible with Device Net and CANOpen
- J2534 Compliant for CAN and ISO15765
- RP1210 Compliant for CAN and J1939
- CCP Protocol Hardware acceleration
- Supports listen-only operations
- Double Buffered CAN transmission
- Industry Standard 9-PIN D-Sub Connector Pin out
- Integrated 1 Meter USB Cable
- Transient and Reverse battery protected
- Green and Red LEDs indicate transmission or reception of USB data.
- LED indicates transceiver power.
- Operational Temperature Range: -40° C to +70°C
- Fully USB powered with **option** for external power 6-40V VDC compatible with 24V industrial systems.
- Isolated Transceiver Side Power Consumption (typical): 15mA @ 14.4 VDC (maximum during bus fault) 100mA @ 14.4 VDC
- On board Processing: 40 MIPS RISC based design
- 64 bit time stamping to an accuracy of 500 nano-seconds for one channel, 5 microseconds for two channel usage. Time stamp never overflows.
- Firmware: Field upgradeable design (flash EEPROM)
- Vehicle Spy Trial Setup Tool for Baud Rates
- Graphical Bit Timing Tool
- CE Compliant
- Warranty: One year limited warranty

Industry Standard Pin-out

Pin	Description	Pin	Description
1	Trigger Pin	6	GND
2	CAN 1 Low	7	CAN 1 High
3	GND	8	CAN 2 High
4	CAN 2 Low	9	V+
5	GND (Shield)		

Ordering Information: ValueCAN Products/Software Products

Part Number	Description
VCAN-DW3	ValueCAN3 with two ISO11898 dual wire CAN channels with Vehicle Spy 3 Trial
VCAN-OBD-J2284	OBD High Speed CAN OBDII/J1962 Cable
VCAN3-OBDII-MSHSCAN	OBD High Speed and Medium Speed CAN OBDII/J1962 Cable
J1939-CABLE	Heavy Duty 9-Pin Deutsch Connector for J1939

For pricing see website. Please contact Intrepid Control Systems for details. Volume discounts and private label distribution agreements available. All trademarks mentioned are trademarks of their respective companies. Specifications subject to change without notice.

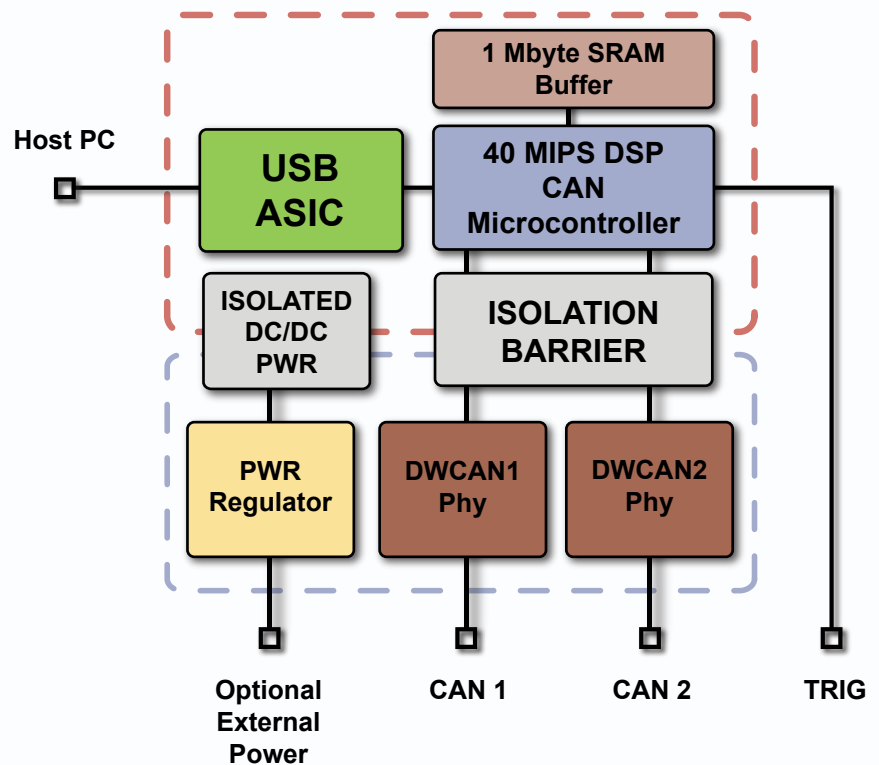

Intrepid Control Systems, Inc.

31601 Research Park Drive Madison Heights, MI 48071 USA (ph) +1-586-731-7950 (fax) +1-586-731-2274

www.intrepidcs.com

Rev.08242011